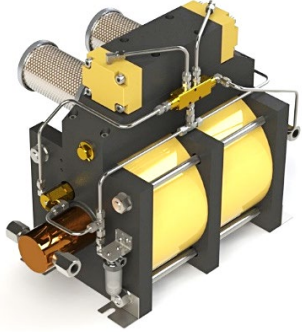

TECHNICAL DATA SHEET

PRODUCT	PU-DHDA33/4-N*-L1**/options	
SERIES	DHDA Double Airhead Double Acting Air operated, high flow, double headed-double acting hydraulic pumps for pressure testing, chemical injection and hydraulic power.	

FEATURES

- Infinitely variable output pressure and flow
- Holds static pressure without generating heat or consuming power
- Standard models are suitable for oil or water applications
- Well proven and trouble-free operation
- Designed for ease of maintenance
- Low cost servicing
- Robust construction

PERFORMANCE DATA

Max Rated Output Pressure	6,728psi (464bar)
Output Per Cycle	15.6 in ³ (256cc)
Max Flow	1,934 in ³ /min (31 litre/min)
Max Air Supply Pressure	100psi (7bar)
Ratio	66 : 1
Air Consumption	200 scfm (5,664 NI/min)

SEAL OPTIONS (N*)

N* (standard)	Nitrile (Buna-N) Main Seal and Check Valve Seals
V	Viton (FKM) Main Seal and Check Valve Seals
C	Chemraz (FFKM) Main Seal and Check Valve Seals

CONSTRUCTION

Air Motor	Anodised Aluminium / Nitrile (Buna-N) Seals
-----------	---

Hydraulic Cylinder	Aluminium Bronze
Piston	Stainless Steel + Corrosion Resistant Chrome Finish
Check Valves	Stainless Steel (Seals as per Selected Seal Option)
Pilot Air Valves	Brass / Stainless Steel Internals / Nitrile (Buna-N) Seals / Stainless Steel Pipework
L1** (standard)	Plated Steel Silencer
L2** (optional)	Stainless Steel Silencer

CONNECTIONS

Hydraulic Inlet	1" NPT(F)
Hydraulic Outlet	1/2" NPT(F)
Air Inlet	1" NPT(F)
Pilot Air Supply	1/8" BSPP(F)
Net Weight	69kg (152lb)

COMMON OPTIONS (BUT NOT LIMITED TO)

/ A	ATEX (94/9/EC) II 2GD c T5
/ F	Panel mount digital stroke counter (non ATEX)
/ G	Panel mount pneumatic stroke counter

GENERAL LAYOUT DRAWING

Model: **PU-DHDA33/4**

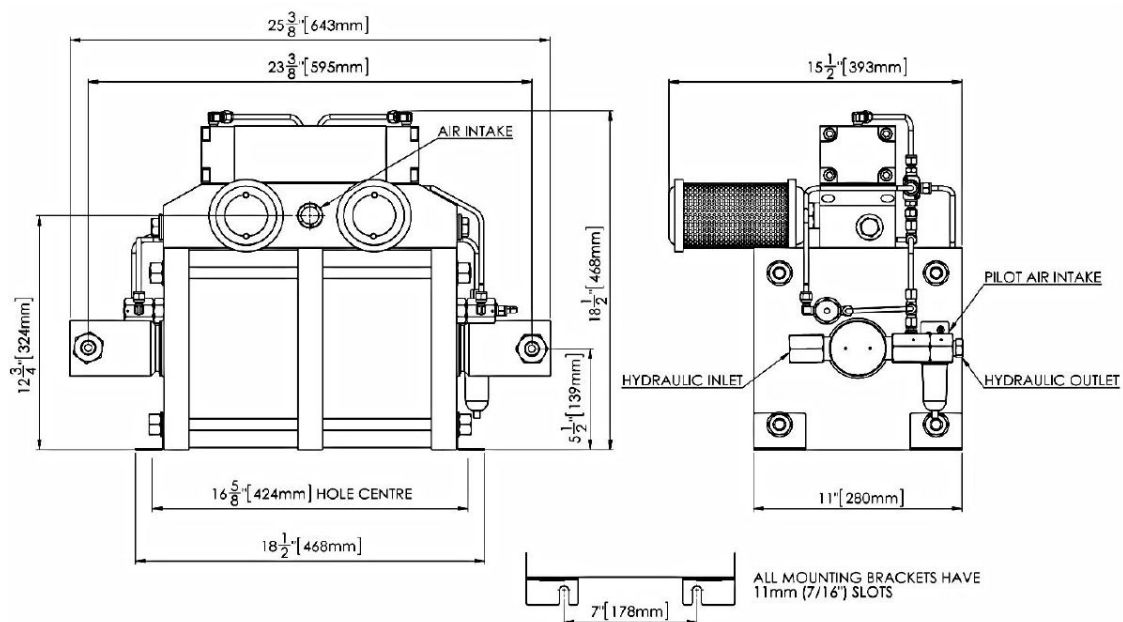

HYDRAULIC PRESSURE STATIC / STALL CONDITIONS

AIR PRESSURE	HYDRAULIC PRESSURE
20psi (1.4bar)	1,346psi (46bar)
40psi (2.8bar)	2,692psi (186bar)
60psi (4bar)	4,036psi (278bar)
80psi (5.5bar)	5,382psi (371bar)
100psi (7bar)	6,728psi (464bar)

FLOW CURVE

DHDA66 – Ratio 66:1

