

## TECHNICAL DATA SHEET

PRODUCT	<b>PU-AZ-1-12H-N*-L**/options</b>	
SERIES	<b>AZ-1 Single Acting</b> Air operated, hydraulic pumps for pressure testing, chemical injection and hydraulic power.	

### FEATURES

- Infinitely variable output pressure and flow
- Will hold static pressure without generating heat or consuming power
- Standard models are suitable for oil or water applications
- Well proven and trouble-free operation

### PERFORMANCE DATA

Max Rated Output Pressure	1,225psi (84.5bar)
Output Per Cycle	2.21 in <sup>3</sup> (36cc)
Max Flow	1,116 in <sup>3</sup> /min (18.3 litre/min)
Max Air Supply Pressure	100psi (7bar)
Ratio	12 : 1
Air Consumption	28 scfm (800 NI/min)

### SEAL OPTIONS (N\*)

N* (standard)	Nitrile (Buna-N) Main Seal and Check Valve Seals
V	Viton (FKM) Main Seal and Check Valve Seals
C	Chemraz (FFKM) Main Seal and Check Valve Seals

### CONSTRUCTION

Air Motor	Anodised Aluminium / Wound Composite / Nitrile (Buna-N) Seals
-----------	---------------------------------------------------------------

Hydraulic Cylinder	Stainless Steel
Piston	Stainless Steel + Chrome Finish
Check Valves	Stainless Steel (Seals as per Selected Seal Option)
L1** (standard)	Plated Steel Air Motor Studs
L2** (optional)	Stainless Steel Air Motor Studs

### CONNECTIONS

Hydraulic Inlet	1"NPT(F)
Hydraulic Outlet	1/2" NPT(F)
Air Inlet	1/2" NPT(F)
Silencer Air Outlet	3/4"NPT(F)
Net Weight	7kg (15.5lb)

### COMMON OPTIONS (BUT NOT LIMITED TO)

/ A	ATEX (94/9/EC) II 2GD c T5
/ L	Low pressure start for air motor
/ N	Greased for life lubricated air motor

### GENERAL LAYOUT DRAWING

Model: **PU-AZ-1-12H**

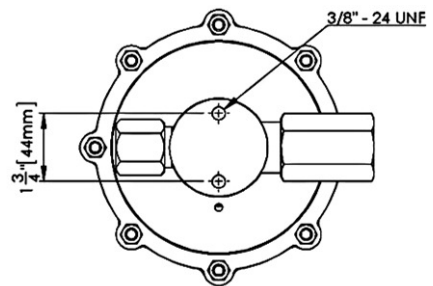
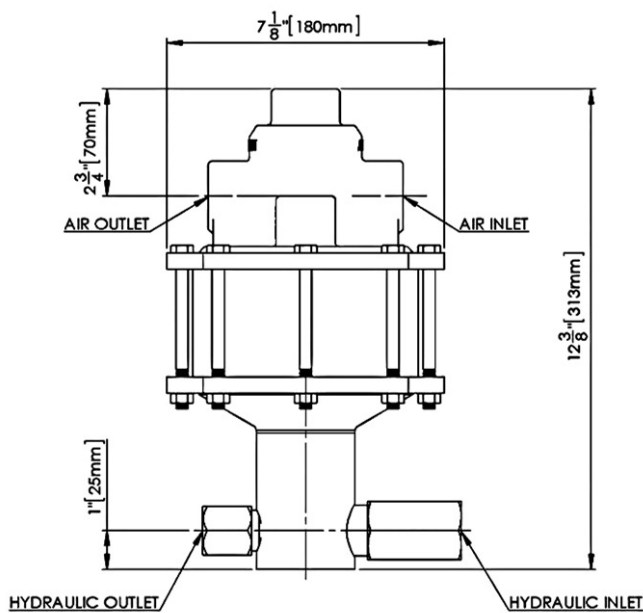

## HYDRAULIC PRESSURE STATIC / STALL CONDITIONS

AIR PRESSURE	HYDRAULIC PRESSURE
20psi (1.4bar)	200psi (13.7bar)
40psi (2.8bar)	450psi (31bar)
60psi (4bar)	700psi (48.3bar)
80psi (5.5bar)	980psi (67.6bar)
100psi (7bar)	1,225psi (84.5bar)

## FLOW CURVE

AZ-1-12 - Ratio 12:1

